

Sales Code: PK350

Description: Round W/H Bath Shower Mixer

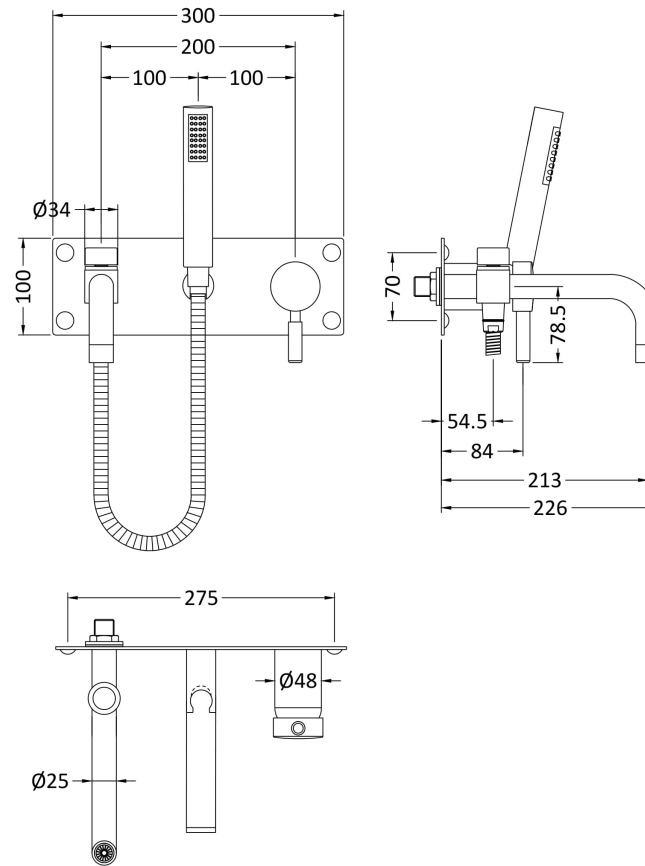

Product Dimensions

Height (mm):	150
Width (mm):	300
Depth (mm):	226
Length (mm):	
Nett Weight (kg):	3.38

Packaging Dimensions

Height (mm):	140
Width (mm):	180
Depth (mm):	350
Gross Weight (kg):	3.38

Packaging Data

Box Colour:	White Cardboard Box
Box Qty:	1
Label Size:	100 x 50
Label Colour:	White Label
Label Qty:	2

Outer Box Dimensions (If Applicable)

Height (mm):	
Width (mm):	
Depth (mm):	
Length (mm):	
Gross Weight (kg):	68
Barcode:	5055146130239

Product Details

Country of Origin:	China
Fitting Instruction:	Yes
Product Material:	Brass/ABS
Control Type:	Manual
Waste Included:	Waste Not Included
Waste Type:	Not Applicable
WRAS Approval: No	Approval No: N/A
Valve/Cartridge Type:	Single Lever Cartridge
Colour/Finish:	Chrome
Mount Type:	Wall
Operating Pressure (bar):	1

Flow Rates: (Litres Per Min)	0.1 bar: 2.5	0.5 bar: 7	1 bar: 10	2 bar: 14.5	3 bar: 18
Pipe Size:	22 mm (3/4" Bsp)				
Pipe Centres:	N/A				