

SENSOR LIQUID SOAP DISPENSER WP173E FOR MOUNTING IN CABINET

87 x 293(255) x 129(121) mm

500 ml or 950 ml soap bottle or 850 ml plug-in tank

- Sensor liquid soap dispenser in robust, germ-reducing and easy-care stainless steel (AISI 316L).
- For mounting in cabinet on site.
- With EWAR® eModule touch-free operated and non-drip soap pump.
- Designed for standard 500 ml or 950 ml disposable bottles of liquid soap or hand lotion. Refillable from the top.
- Also refillable with large container using the plug-in tank as an option.
- eModule battery-powered with two 1.5 V Baby/LR14 batteries. Power supply available as an option.
- Wear parts can be replaced as modules.
- Mounting: With three screws through key holes and one optional anti-theft hole in the back wall.
- Delivery includes fixing material, batteries, self-adhesive information label „Soap“ and first fill with soap.
- Weight, including single package: 1.6 kg



Suggested text for specifications:

Sensor liquid soap dispenser in stainless steel (AISI 316L) for mounting in cabinet. With touch-free operated and non-drip soap pump. Designed for standard 500 ml or 950 ml disposable bottles of liquid soap or hand lotion. Refillable from the top. Delivery includes fixing material, batteries, self-adhesive information label „Soap“ and first fill with soap.

Dimensions: 87 x 293(255) x 129(121) mm

Article No. WP173e

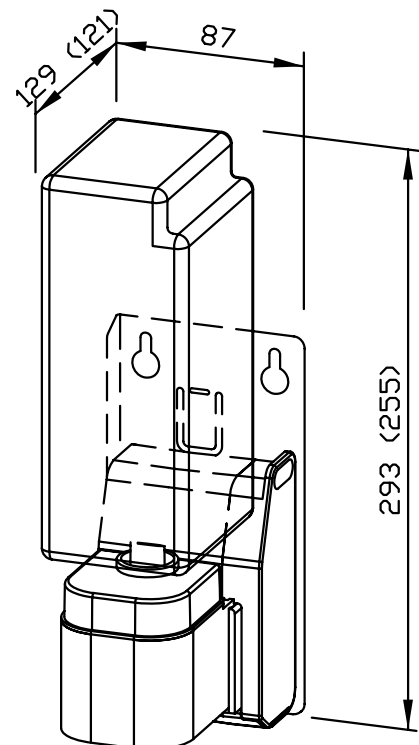

Options	ID No.
Plug-in tank 850 ml	937 201
Power supply for eModule	923 060

Available surface	ID No.
satin finished	727 183